

PIN NO.	PIN NAME
P 1	Supply Voltage Vcc
P 2	Reset (RST)
P 3	Clock (CLK)
P 4	N/A
P 5	Ground
P 6	Programming Voltage Vpp
P 7	I/O
P 8	N/A
S/W	Detect Switch

- Note:
1. Specification:
 - 1.1 Voltage Rating: 50V
 - 1.2 Current rating: 1 A Max.
 - 1.3 Dielectric withstanding voltage: 250 V(ac) for 1 min.
 - 1.4 Contact resistance: 50 mΩ Max.
 - 1.5 Insulation resistance: 1000 MΩ Min.
 - 1.6 Durability: 5000 Cycles
 - 1.7 Temperature range: -30°C~80°C

No.	Name	Material	Finish
3	Shell	Sus201 T=0.12	50u"Min. Ni Plated all;
2	Contact	C5210 T=0.08	50u"Min. Ni underplated all; 1~3u"Min. Au plated Contact Area & Solder tails
1	Housing	LCP S475; Black	UL 94V-0

深圳市华宇创精密电子有限公司

TOLERANCE: X.X ±0.30 X.XX ±0.25 X.XXX ±0.15 X.* ±2* X.X* ±0.5*	DRAWN BY : 陈一鸣	DATE : 2014-02-23	PART NAME: MICRO SIM CARD 9P 1.5H 带检测P	
	CHECKED BY: 马跃	DATE : 2014-02-23	PART NO. HYC363-SIM09-150	MOLD NO.
UNIT: mm [inch] SCALE: 1:1 SIZE: A4	APPROVED BY: 邱敏	DATE : 2014-02-23	DRAW NO: HYC-2405291529	SHEET NO. 1 OF 1

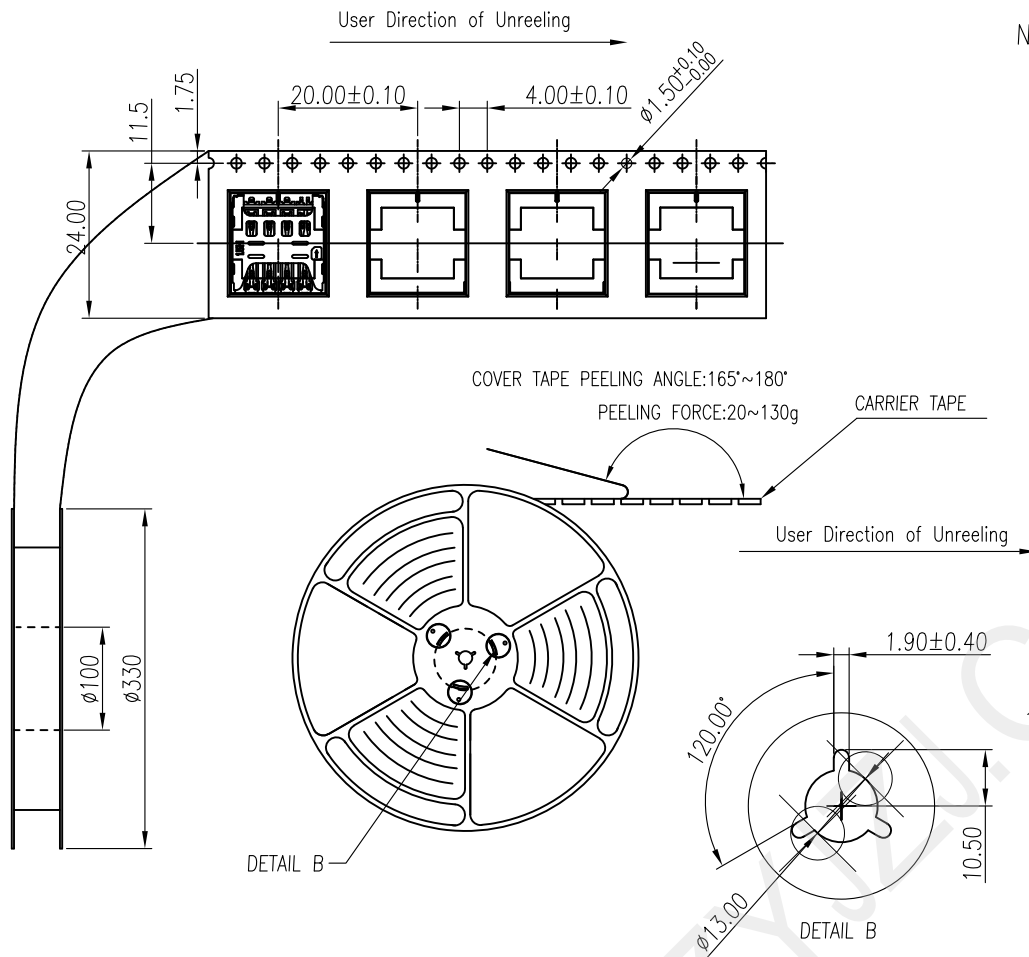

NOTES

1. NUMBER OF CONNECTORS:1500PCS/REEL

2. LEAD TAPE LENGTH

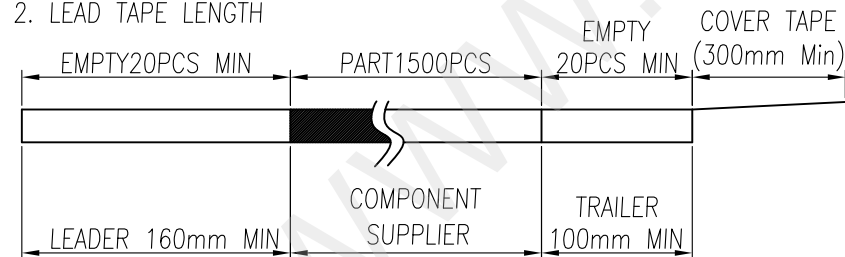

3. QUANTITY:15000PCS/CARTON

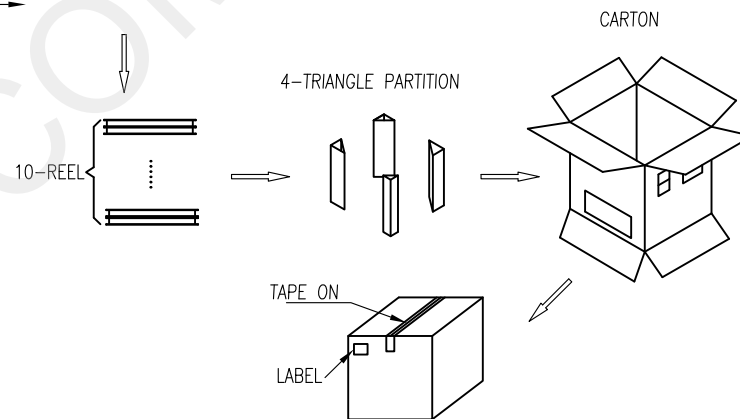

 深圳市华宇创精密电子有限公司			
TOLERANCE: X.X ±0.30 X.XX ±0.25 X.XXX ±0.15 X.* ±2* X.X* ±0.5*	DRAWN BY : 陈一鸣	DATE : 2014-02-23	PART NAME: 包装图
	CHECKED BY: 马跃	DATE : 2014-02-23	PART NO.
UNIT: mm [inch] SCALE:1:1 SIZE: A4	APPROVED BY: 邱敏	DATE : 2014-02-23	MOLD NO.
			DRAW NO:
			SHEET NO. 1 OF 1